

MODEL NUMBER • A-75-B

SERIAL NUMBER 0487821

BURROUGHS SO # 17342

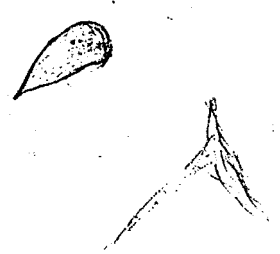

MODEL NUMBER AND SERIAL NUMBER IS NEEDED WHEN
ORDERING SPARE PARTS.

INDEX	PAGE NUMBER
FINAL INSPECTION AND DATA SHEETS.....	3-5
MACHINE OPTIONS - EXTRAS.....	5
HYDRAULIC OIL.....	6
WATER COOLING.....	7
INJECTION SCREW ADJUSTMENT.....	8
LOW PRESSURE CLOSE OF CLAMPING MECHANISM.....	8
CLAMPING MECHANISM.....	9
MOLD EJECTION MECHANISM.....	9
TABLE AND KNOCKOUTS.....	10
PLASTIC CYLINDER POSITIONING AND INJECTION.....	10
INSTALLING THE MOLD.....	11-12
GREASE.....	12
GREASE PUMP.....	13
GREASE INJECTORS.....	14
POWER REQUIREMENTS.....	15
OVERALL RECOMMENDATIONS.....	15
ELECTRICAL WIRING.....	15
BAND HEATERS.....	16
INJECTION PRESSURE.....	17
GENERAL INFORMATION.....	18-19
PLASTIC FEED ADJUSTMENT.....	19
RECOMMENDED ELECTRICAL AND HYDRAULIC SPARE PARTS.....	20
RECOMMENDED MECHANICAL SPARE PARTS.....	21
LIMIT SWITCH LOCATION FRONT VIEW.....	22
LIMIT SWITCH LOCATION SIDE VIEW.....	23
LIMIT SWITCHES.....	24
ASSEMBLY DIAGRAMS:	
a.)SCREW RAM.....	25
b.)CLAMP HEAD.....	26
c.)CARRIAGE SLIDE.....	27
d.)PLASTIC CYLINDER.....	28
e.)PLASTIC STORAGE HOPPER.....	29
f.)DIE-SET.....	30
g.)TABLE ASSEMBLY.....	31
DETAILED PARTS NUMBER SHEETS.....	32-34
INJECTION MOLDING HINTS.....	36
PREPARATION FOR START UP AND PURGE OPERATIONS.....	37-39
AUTOMATIC OPERATION.....	40-42
MANUAL OPERATION.....	42-45
TROUBLE SHOOTING GUIDE.....	46-51
PREVENTATIVE MAINTENANCE CHECK LIST.....	52-55
SCL-100 MAINTENANCE AND TROUBLE SHOOTING.....	56-67

Model A-75-8
Ser # 0487821

75 Ton 803

FINAL INSPECTION AND DATA
TRUEBLOOD PLASTIC INJECTION MOLDING MACHINE

1. CUSTOMER BURROUGHS
2. DATE SHIPPED APRIL, 1987
3. PAINT MAKE LYRICAL BLUE
4. MOLD SHOE SIZE:
TOP 3-7/8"
BOTTOM 5"
MAX MOLD BASE 10 X 13-1/2
5. INJECTION CARRIAGE ADJUSTED TO FIT:
6" X 8" 9 3/4"
6. KNOCKOUT:
NUMBER OF STATIONS 2
LOCATION L/F & R/F
7. NOZZLE CAP:
STYLE SHUT-OFF 113-50012
SIZE 1-1/2
8. SCREW HYDRAULIC MOTOR:
MAKE TRUEBLOOD
MODEL 112-24022
GEAR BOX -NO-
9. TABLE:
TRANSFER Yes 113-26504
INDEX _____
OTHER _____
10. INDEX TABLE MOTOR:
MAKE Trueblood
MODEL _____
11. INDEX TABLE CLUTCH MOTOR:
MAKE Trueblood
MODEL _____
12. INSPECTION:
HOPPER Yes
DIE-SET STOPS Yes
CENTER LINE Yes

FINAL INSPECTION _____

13. PLASTIC CYLINDER HEATER BANDS:

REAR: MAKE Trueblood
NUMBER REQUIRED 2
DIA. 4 1/2 X 4
VOLTS 240
WATTS 1000

MIDDLE: MAKE Trueblood
NUMBER REQUIRED 2
DIA. 4 1/2 X 4
VOLTS 240
WATTS 1000

NOSE: MAKE Trueblood
NUMBER REQUIRED 1
DIA. 4 1/2 X 4
VOLTS 240
WATTS 1000

NOZZLE: MAKE Trueblood
NUMBER REQUIRED 1
DIA. 2-1/2 X 1
VOLTS 240
WATTS 375

14. HYDRAULIC PUMP:

MAKE TRUEBLOOD
MODEL 112-25003

15. ELECTRIC MOTOR:

MOTOR ROTATION Counter clockwise from shaft
location
MAKE TRUEBLOOD
SERIAL NUMBER 112-24010
H.P. 20
R.P.M. 1750
VOLTS 230/460

16. HEAT CONTROLLERS:

MAKE TRUEBLOOD
MODEL 804A
PART NUMBERS: REAR 112-09033
MIDDLE 112-09033
NOSE 112-09033
NOZZLE _____

17. PROCESSOR:

MAKE TRUEBLOOD
MODEL 112-48552

18. EXPANSION:

MAKE TRUEBLOOD -ALLEN BRADLEY SLC
MODEL 112-48553

HYDRAULIC CYLINDERS

DESCRIPTION	QTY	MAKE	BORE	STROKE	PART NUMBER
INJECTION	2	TB	4	6	112-11011
CLAMP	1	TB	5	4	112-11005
SIDE CAM	2	TB	4	1	112-11018
CARRIAGE	1	TB	2 1/2	4	112-11025
TABLE	1	TB	1 1/2	14	112-11021
KNOCKOUT	2	TB	2	4 1/2	112-11015
SHUT OFF	1	TB	1 1/2	3	112-11019
SIDE K.OUT					

EXTRAS

1. () KVA TRANSFORMER IF LEAD-IN IS OTHER THAN 230V.. _____
2. HYDRAULIC SHUT-OFF NOZZLE..... X
3. AUTOMATIC CENTRAL LUBRICATION SYSTEM..... _____
4. VISUAL INDICATING LIGHTS FOR RELAYS AND VALVES..... _____
5. AUTOMATIC AIR BLAST..... _____
6. THREE COMPLETE SPEED CONTROLS..... X
7. OSHA TYPE SAFETY GUARDS WITH COLOR CODE AND SIGNS... X
8. AUTOMATIC SHUT -DOWN AND PURGING UNIT..... X
9. SET OF (4) FLOOR MOUNTS..... X
10. WATER SAVER AND WATER SAFETY SHUT-OFF VALVE..... _____
11. WATER MANIFOLD AND HOSE..... X
12. THREE GLYCERINE FILLED GAGES..... X
13. PRODUCTION COUNTER... (TYPE)..... X
14. COMPLETE SCREW SUCK BACK ARRANGEMENT UNIT..... X
15. HYDRAULIC KNOCKOUT SYSTEM..... X
16. EMERGENCY STOP CONTROL..... _____
17. SAFETY GATE START CONTROL..... X
18. GAGE ISOLATORS..... 3 X
19. LOW PRESSURE CLOSE ON CLAMPING HEAD..... X
20. CENTER POST..... _____
21. ROTARY WATER VALVE..... _____
22. EXTRA CYCLE START BUTTONS..... _____
23. WATER TEMPERATURE GAGE FOR BLOCK..... X
24. OIL LEVEL AND TEMPERATURE GAGES..... X
25. DUAL SNAP PRESSURE SWITCH..... _____
26. SIDE EJECTORS..... _____
27. OPERATING MANUAL, ELECTRIC AND HYDRAULIC CIRCUIT.... _____
28. ALL OSHA WARNING SIGNS ATTACHED IN PROPER POSITION.. X

HYDRAULIC OIL

THE OIL TANK IS BUILT PERMANENTLY INTO THE BASE OF THE MACHINE. IT HAS BEEN DESIGNED USING THE LATEST INFORMATION ON HYDRAULIC RESERVOIRS, WITH METAL MAGNETS AND FILTERS UNDER THE INTAKE COVER PLATE.

NOTE: THE OIL HAS BEEN REMOVED FOR SHIPPING PURPOSES AND UNDER NO CIRCUMSTANCES SHOULD THE MOTOR PUMP BE RAN UNTIL THE TANK IS FILLED TO THE PROPER LEVEL WITH THE BEST GRADE OF HYDRAULIC OIL AVAILABLE. THE FOLLOWING LIST CONTAINS A FEW SUPPLIERS AND OIL TYPES WHICH ARE ACCEPTABLE FOR USE IN THE MACHINE:

<u>SUPPLIER</u>	<u>TRADE NAME</u>
STANDARD OIL CO.	AW-100
STANDARD OIL CO. (CALIF)	UTILITY-15
PENNZOIL COMPANY	AW-68
SHELL OIL COMPANY	TELLUS-68

IF OTHER SUPPLIERS AND OIL TYPES ARE USED, THE FOLLOWING INFORMATION SHOULD BE GIVEN TO THE SUPPLIER TO ASSURE AN EQUIVALENT QUALITY HYDRAULIC OIL IS USED.

NOTE: IMPORTANT: HIGH QUALITY RUST AND OXIDATION INHIBITED, LIGHT HYDRAULIC OIL FOR HYDRAULIC PUMP UNITS, PARAFFINE BASE. VISCOSITY 315 S.U.S. AT 100 deg. F.

THE CAPACITY OF THE OIL TANK IS 60 GALLONS, DEPENDING ON THE MODEL. TO FILL THE TANK, REMOVE SEALER CAP BY TURNING COUNTERCLOCK WISE AND POUR OIL THROUGH THE SCREEN UNTIL OIL APPEARS AT THE CENTER OR HIGH LEVEL ON THE OIL GAGE. THE OIL LEVEL GAGE IS LOCATED ON THE OUTER RIGHT-HAND SIDE OF THE MACHINE, BELOW THE FILLER CAP. NEVER POUR OIL DIRECTLY INTO THE OIL TANK WITHOUT SCREENING. A CLEAN OIL SYSTEM IS A MUST IF YOUR MACHINE IS TO GIVE LONG TROUBLE FREE SERVICE.

THE OIL LEVEL SHOULD BE APPROXIMATELY 3/4 HIGH IN OIL LEVEL GAGE. THE OIL TEMPERATURE SHOULD NEVER EXCEED 130 deg F.



9215 S. State Route 201 • Tipp City Ohio 45371 • Phone (513) 845-3573

WATER COOLING

YOUR NEW TRUEBLOOD MOLDING MACHINE IS EQUIPPED WITH AN OVERSIZE HEAT EXCHANGER FOR COOLING THE OIL AND WATER HOLES IN THE INJECTION CYLINDER SUPPORT TO PREVENT THIS BLOCK AND ITS CARRIAGE FROM BECOMING OVER-HEATED. TWO EXTERNAL CONNECTIONS ARE PROVIDED ON THE RIGHT-HAND SIDE OF THE MACHINE. IT IS IMPORTANT THAT THESE BE INSTALLED CORRECTLY, AS MARKED WITH TAGS.

JUST ABOVE THE TWO EXTERNAL WATER CONNECTIONS IS A WATER SHUT-OFF VALVE. THIS VALVE WILL NOT SHUT-OFF THE WATER TO THE COOLER. IT'S ONLY PURPOSE IS TO RESTRICT THE FLOW OF WATER THROUGH THE PLASTIC CYLINDER SUPPORT BLOCK. THE CUSTOMER MUST INSTALL AN EXTERNAL SHUT-OFF VALVE IN THE WATER LINE, IF DESIRED. ONLY ENOUGH WATER SHOULD BE PASSED THROUGH THE INJECTION CYLINDER SUPPORT TO PREVENT THE BLOCK FROM BECOMING TOO HOT. TOO MUCH WATER THROUGH THE BLOCK WILL CAUSE THE HEATER BANDS TO BE ON MORE THAN NECESSARY. WE SUGGEST A TEMPERATURE OF 75 deg TO 100 deg BE MAINTAINED IN THIS SUPPORT BLOCK. ADAIL TYPE THERMOMETER HAS BEEN INSTALLED IN THIS BLOCK TO ASSIST IN CONTROLLING THE TEMPERATURE. THE TEMPERATURE RANGE MENTIONED SHOULD BE USED AS A SUGGESTED POINT ONLY, DEPENDING ON THE TYPE OF PLASTIC BEING USED. LOW MELT PLASTICS SHOULD RUN COOLER. HIGH MELT PLASTICS SHOULD RUN HOTTER ON THE WATER CONTROL READING, SUCH AS 100 deg TO 130 deg F.



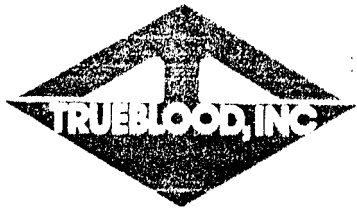

9215 S. State Route 201 • Tipp City, Ohio 45371 • Phone (513) 845-3573

INJECTION SCREW ADJUSTMENT

THE PLASTIC INJECTION SCREW SUPPORT BLOCK RIDES IN HARDENED GUIDE RAILS WHICH HAS ADJUSTING SCREWS IN FRONT TO PERMIT THE STOPPING POSITION OF THE INJECTION CYLINDER TO BE AVAILABLE. THIS ADJUSTMENT IS NECESSARY TO PERMIT THE PROPER CONTACT BETWEEN THE NOZZLE AND THE SPRUE PLATES IN THE MOLD TO BE ACHIEVED. IMPROPER CONTACT BETWEEN THESE DETAILS WILL RESULT IN DAMAGE TO THE MOLD OR PLASTIC LEAKAGE DURING THE INJECTION CYCLE, CAUSING INCOMPLETE MOLDINGS.

ADJUSTMENT OF THE NOZZLE IS MADE BY TURNING THE TWO BUMPER SCREWS AT THE FRONT OF THE CYLINDER CARRIAGE BLOCK. CAUTION SHOULD BE USED TO MAKE SURE BOTH SCREWS ARE SEATING TOGETHER FOR PROPER ALIGNMENT WITH NOZZLE SEATING IN MOLD SPRUE BLOCKS.

INJECTION SCREW ADJUSTMENT SHOULD ONLY BE ATTEMPTED WHEN OPERATING THE MACHINE ON THE MANUAL-SIDE OF THE ELECTRICAL SYSTEM. IF THE INJECTION PRESSURE HAS NOT BEEN SET TOO HIGH, THIS ADJUSTING MAY BE EXECUTED WITH THE PLASTIC SCREW IN ITS FORWARD POSITION.

THIS MACHINE SHOULD NEVER BE OPERATED IN AUTOMATIC CYCLE UNTIL THE ABOVE ADJUSTMENT HAS BEEN MADE CORRECTLY IN MANUAL OPERATION.

AFTER EACH FORWARD INJECTION STROKE THE PLASTIC SCREW MUST WITHDRAW APPROXIMATELY 7/8" FROM THE MOLD.

LOW PRESSURE CLOSE OF CLAMPING MECHANISM

THIS MACHINE IS EQUIPPED WITH LOW PRESSURE CLOSING OF THE CLAMPING MECHANISM. THIS IS A RESULT OF THE DUAL PRESSURE HYDRAULIC SYSTEM. THE CLAMPING MECHANISM IS CLOSED ON THE LOW PRESSURE UNTIL THE TOP MOLD SHOE IS ALMOST TOUCHING THE BOTTOM MOLD SHOE. IF THERE IS NO FOREIGN OBJECT BETWEEN THE SURFACES OF THE MOLD, HIGH PRESSURE IS APPLIED COMPLETING THE CLOSING OPERATION. THIS FEATURE PREVENTS SERIOUS DAMAGE TO THE MOLD. AS IN A CASE OF WHERE A TERMINAL OR INSERT IS ACCIDENTALLY LEFT ON TOP OF THE MOLD, THE CLAMP WILL NOT CLOSE COMPLETELY AND RETURNS TO NORMAL POSITION.

THE LOW PRESSURE IS ADJUSTED BY A RELIEF VALVE LOCATED ON THE clamp close/open MANIFOLD. THE LOW PRESSURE WAS PRE-SET BY THE MACHINE BUILDER AT 150 P.S.I. THIS PRESSURE SHOULD NOT BE INCREASED SINCE HIGHER SETTINGS WOULD RENDER THE LOW PRESSURE CLAMPING FEATURE USELESS.



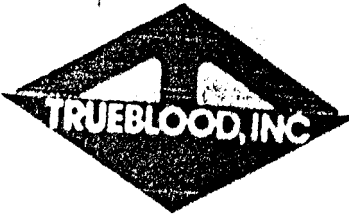

9216 S. State Route 201 • Tipp City Ohio 45371 • Phone (513) 845-3573 • Telex 288-337

CLAMPING MECHANISM

WHEN THE CLAMPING HEAD IS LOWERED THE LIMIT SWITCH ON TOP OF MACHINE MUST BE CONTACTED TO BRING IN THE LOCKING CAMS. THE CLAMPING HEAD WILL NOT LOWER IF THE LIMIT SWITCH IN THE MIDDLE OF THE TABLE IS NOT CONTACTED. THE CLAMPING HEAD WILL NOT RAISE IF BOTH LOCKING CAMS ARE NOT RETURNED AND CONTACT THE LIMIT SWITCHES ON THE OUTSIDE OF THE "C" FRAME. THE SPEED OF THE CLAMPING HEAD CYLINDER IS CONTROLLED BY THE NEEDLE VALVE ABOVE THE "C" FRAME NEAR THE CLAMPING HEAD CYLINDER. THIS VALVE WILL BE VERY USEFUL TO CONTROL THE CLAMPING HEAD WHEN ALIGNING THE UPPER AND LOWER MOLD SHOES.

MOLD EJECTION MECHANISM.

THIS TRUEBLOOD HOLDING MACHINE IS EQUIPPED WITH A HYDRAULIC KNOCKOUT WHICH IS FAR MORE VERSATILE THAN THE MECHANICAL KNOCKOUT ON OTHER MACHINES. THIS KNOCKOUT STROKE IS ADJUSTABLE FROM 0 TO 3 1/2. AS THE SHIFTING TABLE MOVES TO THE UNLOADING AND LOADING POSITION THE KNOCKOUT PINS ARE ACTUATED. SINCE THERE ARE TWO LOADING AND UNLOADING POSITIONS, EACH HAS ITS OWN KNOCKOUT MECHANISM THAT OPERATES INDEPENDENT OF THE OTHER.

TO ATTAIN THE DESIRED KNOCKOUT STROKE, LOCATE ON EACH SIDE THE KNOCKOUT PLATE FASTENED TO THE ROD OF A HYDRAULIC CYLINDER. MOUNTED ON THE KNOCKOUT PLATE IS AN ADJUSTMENT TO VARY THE STROKE. LOOSEN THE KNOB SCREW AND ADJUST THE SLIDING BLOCK UP TO DECREASE THE STROKE AND DOWN TO INCREASE THE STROKE. BE SURE TO TIGHTEN THE KNOB SCREW AFTER ADJUSTING. THE KNOCKOUT CYLINDER WILL RAISE EACH TIME THE TABLE IS TRANSFERRED (IF THE "PINS" SWITCH IS IN THE HOLD OR FULL POSITION) IF THE LIMIT SWITCH (L.S. 4) IN THE MIDDLE OF THE TABLE IS ACTUATED. THE KNOCKOUT CYLINDER WILL LOWER (WITH "PINS" SWITCH IN THE "FULL" POSITION) ONLY IF THE HEIGHT ADJUSTMENT ACTUATES THE LIMIT SWITCH (L.S. 1 OR 2). THERE IS ALSO THE SELECTIVITY OF BEING ABLE TO HAVE THE KNOCKOUT PIN RAISE AND THEN LOWER (FULL) OR TO RAISE AND BE MAINTAINED (HOLD) IN THIS POSITION UNTIL THE TRANSFER TABLE IS ACTUATED EITHER ON MANUAL OR AUTOMATIC CYCLE. THIS CAN BE ACCOMPLISHED BY PLACING THE SELECTOR SWITCH LOCATED ON THE MAIN PUSHBUTTON PANEL MARKED "HOLD-OFF-FULL" IN THE DESIRED POSITION.





9215 S. State Route 201 • Tipp City, Ohio 45371 • Phone (513) 845-3573

TABLE AND KNOCKOUTS

WITH SELECTOR SWITCH IN "FULL" OR "HOLD" THE KNOCKOUT CYLINDER WILL RAISE EACH TIME THE TABLE IS TRANSFERRED IF THE LIMIT SWITCH (L.S. 4) IN THE MIDDLE OF THE TABLE IS CONTACTED. THE KNOCKOUT CYLINDER WILL LOWER IF THE LIMIT SWITCH BELOW THE TABLE IS CONTACTED ON THE UPWARD STROKE. THE HEIGHT OF THE KNOCKOUT CYLINDERS MAY BE ADJUSTED BY LOOSENING THE KNOB SCREW AND MOVING THE LOWER BLOCK ON THE KNOCKOUT CYLINDER MECHANISM.

THE TABLE WILL TRANSFER ONLY IF THE CLAMPING HEAD IS UP (CONTACTING L.S. 33), BOTH K.O. CYLINDERS ARE IN THE RETRACTED POSITION (L.S. 1 OR 2) AND THE CARRIAGE IS ALL THE WAY RETRACTED (L.S. 12).

THE SPEED OF THE TABLE IS CONTROLLED BY THE NEEDLE VALVE AT THE RIGHT FRONT END OF THE MACHINE TO THE SIDE OF THE PUSHBUTTON CONTROL PANEL.

THE TRANSFER TABLE CYLINDER IS EQUIPPED WITH A SPRING CENTERED DIRECTIONAL VALVE TO ALLOW THE OPERATOR TO JOG THE TABLE IN "HAND" OPERATION TO THE CENTER OF THE TABLE. THIS ENABLES THE FURGING OF THE PLASTIC CYLINDER TO BE DONE BETWEEN THE MOLD SHOES. PUT THE SELECTOR SWITCH IN "ON" POSITION MARKED "JOG". THIS ELIMINATES THE SHOCK FROM THE CYLINDER AND SHOULD ALWAYS BE APPLIED WHEN JOGGING THE TABLE IN MANUAL POSITION.

PLASTIC CYLINDER POSITIONING AND INJECTION

THE PLASTIC CYLINDER CARRIAGE IS MOVED INTO POSITION BY THE HYDRAULIC CYLINDER CONNECTED TO THE PLASTIC SCREW CARRIAGE BLOCK AND BRACKET MOUNTED TO THE BASE OF THE MACHINE.

WHEN THE PLASTIC SCREW MOVES INTO POSITION A LIMIT SWITCH (L.S. 9) TO THE LEFT OF THE PLASTIC SCREW CARRIAGE BLOCK IS CONTACTED AND CALLS FOR THE INJECTION CYLINDER TO MOVE FORWARD TO FILL THE MOLD AND THE AUTOMATIC SHUT-OFF IS OPENED ALSO.)





9215 S. State Route 201 • Tipp City, Ohio 45371 • Phone (513) 845-3573

IF APPROXIMATELY IN LINE, CLOSE MOLD SLOWLY ALLOWING THE TOP MOLD TO SHIFT AND ALIGN ITSELF WITH THE BOTTOM MOLD. TIGHTEN THE FOUR MOUNTING SCREWS AND OPEN THE CLAMP. CLAMP HEAD SHOULD BE CYCLED SEVERAL TIMES SLOWLY FOR FINAL INSPECTION OF SETUP.

NOW PLACE THE SECOND BOTTOM MOLD ON THE TRANSFER TABLE AND TURN MOUNTING SCREWS UNTIL THEY ARE SNUG. MOLD SHOULD BE ABLE TO BE MOVED BY HAND. TRANSFER TABLE TO MOLDING POSITION SLOWLY CLOSING THE CLAMP BY HAND UNTIL MOLD IS COMPLETELY CLOSED. TIGHTEN MOUNTING SCREWS AND OPEN AND CLOSE SEVERAL TIMES TO CHECK ALIGNMENT. THE TABLE TOP SCREW LOCATED AT THE OPPOSITE END OF THE TABLE MAY OR MAY NOT REQUIRE ADJUSTMENT WHEN INSTALLING THE SECOND BOTTOM MOLD.

CAUTION: AFTER THE MOLD INSTALLATION IS COMPLETED, BE SURE THE LIMIT SWITCH (L.S.4) LOCATED IN THE MIDDLE OF THE TRANSFER TABLE, IS STILL BEING ACTUATED EACH TIME THE TABLE MOVES FROM END TO END. ADJUSTABLE PLATES LOCATED AT EACH END OF THE TABLE MUST BE ADJUSTED TO ACTUATE THIS SWITCH TO ALLOW THE MACHINE TO CYCLE. DO NOT OVERACTUATE THIS LIMIT SWITCH, WITH THE ADJUSTMENT PLATES.

GREASE

A HIGH QUALITY HI/TEMP GREASE SHOULD BE USED.

EXAMPLE: 01 BEARING GARD LT BY STANDARD OIL COMPANY (OHIO) OR ITS EQUIVALENT.

REFER TO MANUAL ON MANUAL GREASE POINTS. THESE AREAS SHOULD BE GREASED ONCE A WEEK. ANY QUESTIONS PLEASE CALL:

TRUEBLOOD, INC., SERVICE DEPT.

TIPP CITY, OHIO 45371

telephone: (513) 845-3573

or 845-9472



POWER REQUIREMENTS
AMPS PER MACHINE

CUSTOMER'S INCOMING VOLTAGE 240 VOLTS
ELECTRICAL MOTOR: 20 H.P. 1750 R.P.M. 240/480 VOLTS
240 WIRED FOR
CIRCUIT TRANSFORMER 1 KVA
HEATERS TRANSFORMER KVA
HEATERS TOTAL WATAGE 5375

TOTAL 76.6 AMPS

OVERALL RECOMMENDATIONS

PM CHECK LIST SHOULD REDUCE FUTURE DOWN TIME OF MACHINERY. LISTED PROCEDURES SHOULD BE AN ASSET TO MAINTAINING EQUIPMENT AND REDUCING OVERALL COST OF MAINTENANCE AND PARTS. MAINTAINING CLEAN MACHINERY WILL ASSIST IN RECOGNIZING HYDRAULIC LEAKS AND POSSIBLE DAMAGED COMPONENTS. MOST RECOMMENDED SPARE PARTS ARE AVAILABLE AT TRUEBLOOD, INC. HOWEVER, DUE TO THE DELETION OF STOCK ITEMS AT TIMES, BY LARGE ORDERS MAY REQUIRE CUSTOMER TO ORDER IN ADVANCE TO REDUCE DOWN TIME OF EQUIPMENT AND PRODUCTION.

ELECTRICAL WIRING

YOUR TRUEBLOOD PLASTIC INJECTION MOLDING MACHINE HAS BEEN COMPLETELY WIRED AND TESTED. IT IS BEING SHIPPED WITH ALL CONNECTIONS INTACT. IT WILL BE NECESSARY FOR THE CUSTOMER TO PROVIDE A 240 V, 3 PHASE, 60 CYCLE POWER SUPPLY WITH A 100 AMP CAPACITY TO THE MAIN CONTROL PANEL.

NOTE: IF ANY OF THE CONNECTIONS HAVE BEEN BROKEN DURING SHIPMENT, OR ARE REMOVED BY THE CUSTOMER, THEY MUST BE REPLACED CORRECTLY. THE DIRECTION OF ROTATION OF THE 20 HP ELECTRIC MOTOR IS VERY IMPORTANT TO PREVENT DAMAGE TO THE HYDRAULIC PUMP CHECK THE DIRECTION OF ROTATION BEFORE ALLOWING THE MOTOR PUMP TO RUN CONTINUOUSLY. AN ARROW ON THE PUMP ILLUSTRATES THE CORRECT ROTATING DIRECTION.



9215 S. State Route 201 • Tipp City, Ohio 45371 • Phone (513) 845-3573

THE SELECTOR SWITCH LOCATED ON THE MAIN PUSHBUTTON PANEL MARKED "HAND-OFF-AUTO" MUST BE IN THE "OFF" POSITION TO START THE MOTOR.

PLASTIC FEED ADJUSTMENT

LOCATED AT RIGHT-SIDE OF SCREW SET WITH ADJUSTABLE LIMIT SWITCH.

IN ORDER TO OBTAIN MAXIMUM EFFICIENCY OF THE MOLDING CYCLE, IT IS VERY IMPORTANT THAT THE FEED BE ADJUSTED TO DELIVER THE PROPER AMOUNT OF PLASTIC TO THE HEATING CHAMBER OF EACH SHOT. TO DO THIS, FIRST FILL THE MAIN HOPPER WITH PLASTIC. IT'S CAPACITY IS APPROXIMATELY 50 POUNDS.

IF, FOR ANY REASON IT BECOMES NECESSARY TO REMOVE PLASTIC FROM THE MAIN HOPPER, MOVE SLIDE LOCATED BELOW THE HOPPER TO THE "OFF" POSITION.



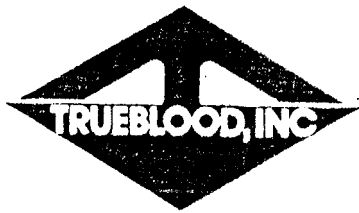

9215 S. State Route 201 • Tipp City, Ohio 45371 • Phone (513) 845-3573

RECOMMENDED SPARE PARTS ELECTRICAL AND HYDRAULIC

- A. LIMIT SWITCHES WILL REPLACE ANY LIMIT SWITCH ON PRESS
1. 802T-NP
 2. 802T-A
 3. 802T-C
 4. BZV6-2R08
 5. BZE6-2R08
- B. SETS OF ROD SEALS ASSORTED SIZES
WILL REPLACE ALL CYLINDERS USED FOR LEAKS AROUND CYLINDER
RODS.
- C. CONTACT BLOCKS WILL REPLACE CONTACTS ON ALL PUSHBUTTONS
1. (2) N.O. CONTACTS #BJK
 2. (2) N.C. CONTACTS #BJJ
- D. COILS FOR DIRECTIONAL VALVES WILL FIT ANY DIRECTIONAL
VALVE
- E. SMALL INDICATING LIGHTS FOR RELAYS AND DIRECTIONAL VALVES
1. (2) AMBER
 2. (2) RED
- F. INSTRUMENTS FOR HEATERS WEST OR BARBER-COLMAN
- G. COIL FOR FLUID POWER VALVES CLAMP HIGH PRESSURE AND TABLE
JOG.
- H. PULL-PUSH SWITCH FOR STOP OR START (51JAPRJU)
- I. U.S. GAUGE 2 1/2" PRESSURE REDUCING VALVES.
- J. THERMOCOUPLE FOR HEATERS.
- K. POPPET & SPRING FOR CHECK VALVES FOR PILOT CHECK VALVES.
- L. SETS OF "O"RINGS FOR DIRECTIONAL VALVE
1. (1) SET FOR SMALL VALVES
 2. (1) SET FOR LARGE VALVES
- M. HEATER BAND
SIZE _____ WATTS _____ VOLTS 230
- N. DIRECTIONAL VALVES
1. Inject #DG-5S4-0066C-50
 2. Side cams, Carriage, & Nozzle #DG-4S4-012A-50
 3. Clamp #DG-4S4-012C-50
 4. Table & K.O. Pins #DG-4S4-0133C-50
- O. SCREW TIP ASSEMBLY
SIZE DEPENDS UPON DIAMETER OF SCREW.
- P. WRENCH KIT FOR SCREW DISASSEMBLY AND OTHER FITTINGS ON
MACHINE.





9215 S. State Route 201 • Tipp City, Ohio 45371 • Phone (513) 845-3573

RECOMMENDED MECHANICAL SPARE PARTS

- A. SHUT-OFF NOZZLE CAP ASSEMBLY, WITH NOZZLE TIP.
- B. INJECTION SCREW.
- C. INJECTION BARREL.
- D. SCREW MOTOR.
- E. INJECTION SCREW TIP ASSEMBLY.
- F. CLAMP HEAD LOCKING INSERTS, (2) EACH
- G. SIDE LOCKING CAMS, (2) EACH
- H. SIDE LOCKING CAM BLOCKS, (2) EACH
- I. REAR ROLLER BEARING, (1) EACH - CHECK TO BE SURE ON TYPE
OF BEARING USED.
- J. FRONT BEARING

NOTE: ABOVE PART SIZES DEPEND UPON MODEL OF THE MACHINE.
PLEASE STATE MODEL AND SERIAL NUMBER OF MACHINE WHEN
ORDERING PARTS.





9215 S. State Route 201 • Tipp City, Ohio 45371 • Phone (513) 846-3573 • Telex 288-337

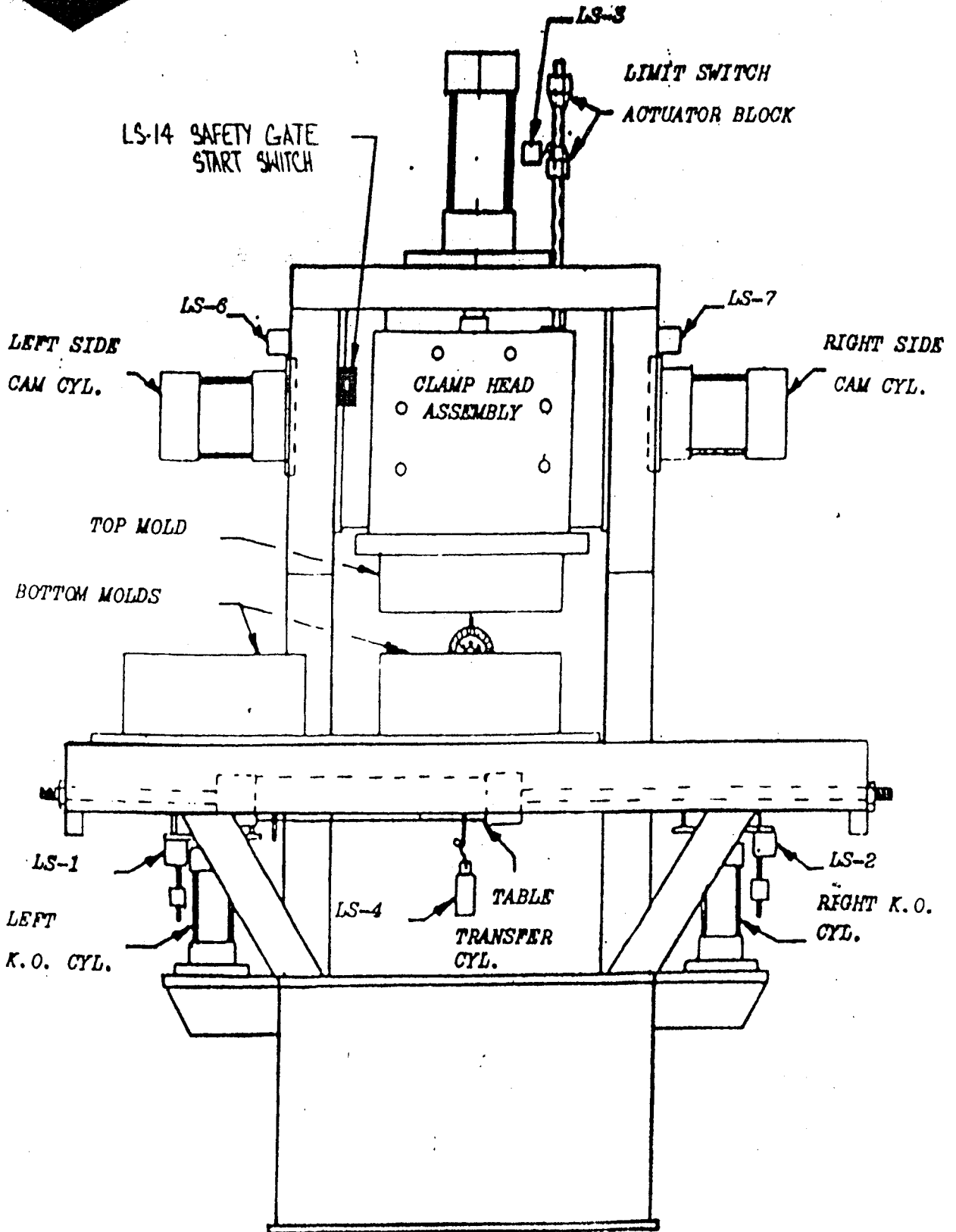

TRUEBLOOD, INC.

1111 E. Erie Park, P.O. Box 211, Lima, Ohio 45171 Phone (513) 846-3573

INJECTION PANEL ENCLOSURE

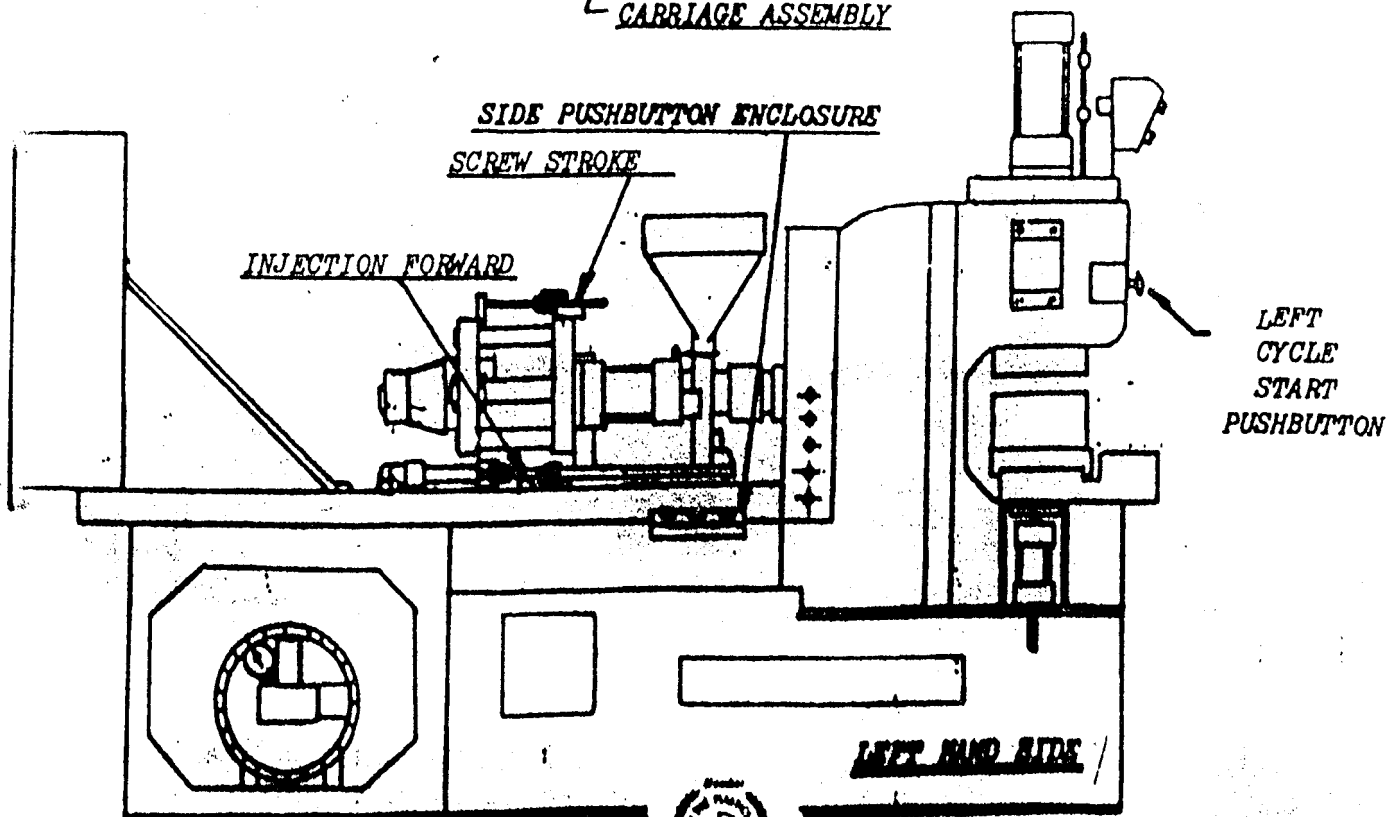
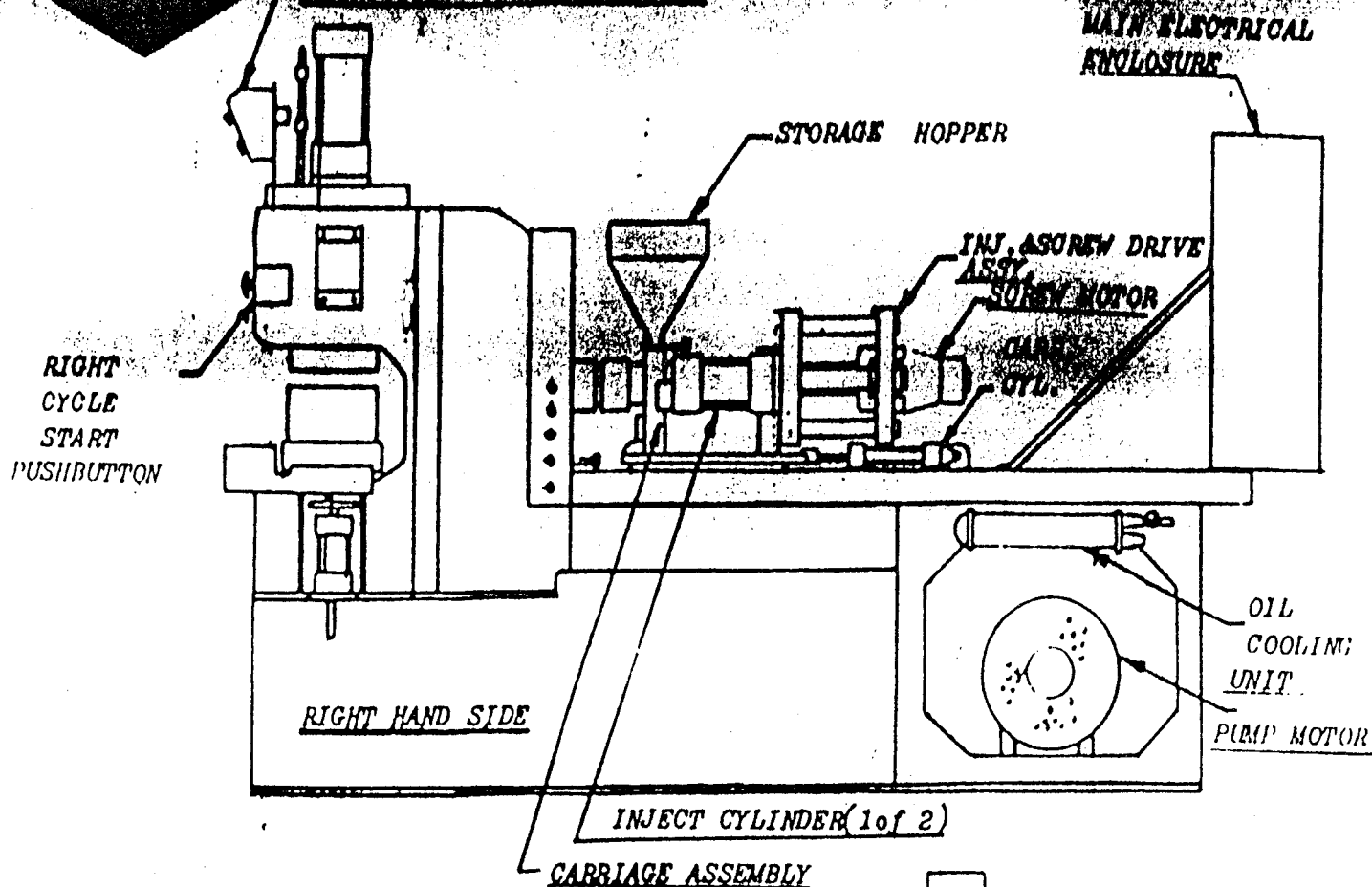

X

LIMIT SWITCHES

NO.	DESCRIPTION	PART-NO.	BRAND
LS-1	PINS LEFT	802T-NP	ALLEN-BRADLEY
LS-2	PINS RIGHT	802T-NP	ALLEN-BRADLEY
LS-3	CLAMP OPEN/CLOSE	802T-NP	ALLEN-BRADLEY
LS-4	TABLE LEFT/RIGHT	802T-NP	ALLEN-BRADLEY
LS-6	CAM LEFT	802T-C	ALLEN-BRADLEY
LS-7	CAM RIGHT	802T-C	ALLEN-BRADLEY
LS-8	SCREW STROKE	BZE6-2R08	MICRO-SWITCH
LS-9	CARRIAGE FWD/BACK	802T-NP	ALLEN-BRADLEY
LS-14	FRONT GUARD	BZE6-2R08	MICRO-SWITCH
LS-16	GUARD DOOR	BZE6-2R08	MICRO-SWITCH
LS-17	GUARD DOOR	BZE6-2R08	MICRO-SWITCH



921 S. State Road # 201 • Tipp City, Ohio 45371 • Phone (513) 845-3573 • Telex: 288-337

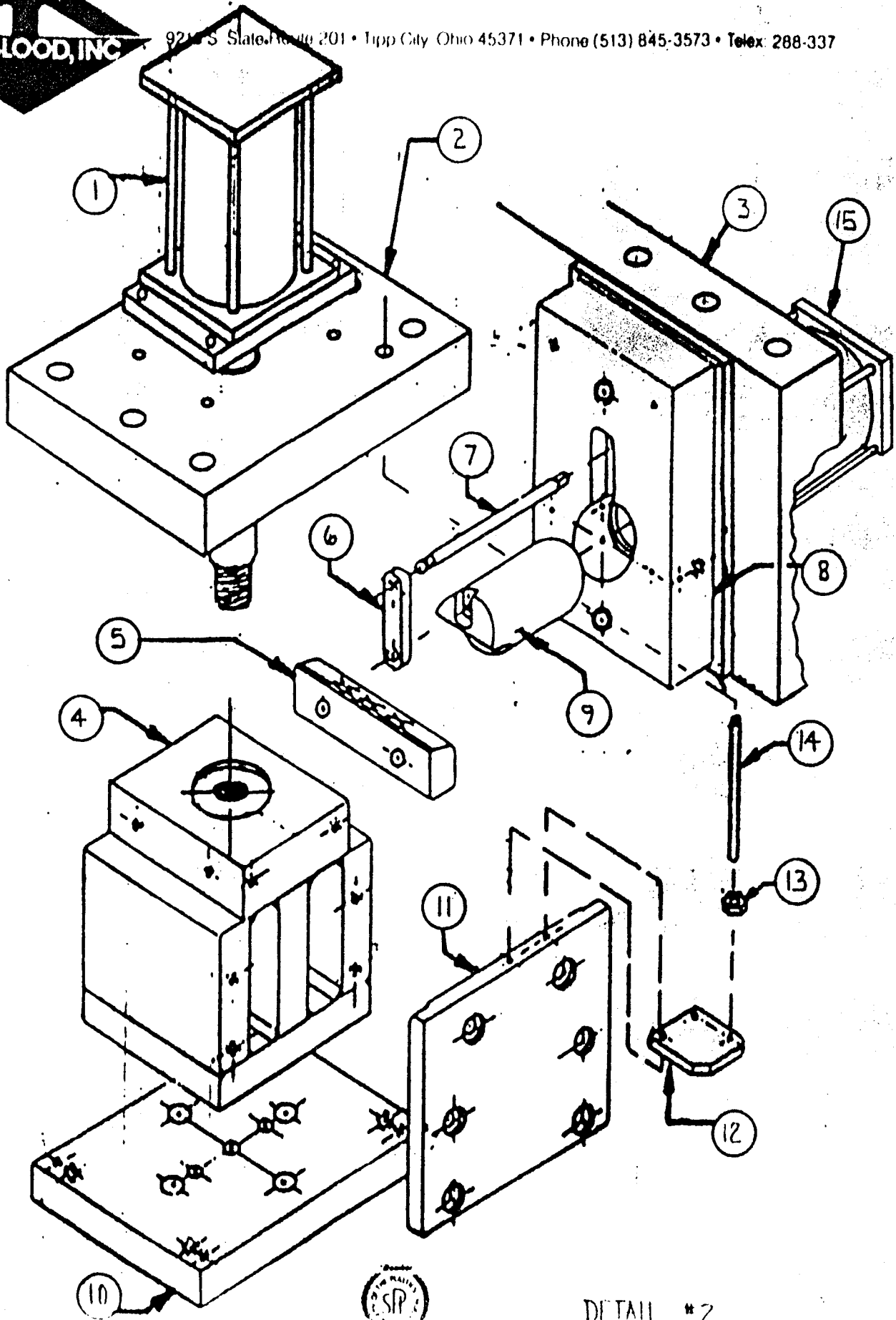

DETAIL #2



26	1	SCREW DRIVE MOTOR
27	1	MATERIAL HOOPER
24	1	DOME DIA
25	1	CYLINDER MOUNT
24	2	SAFETY STOP BLOCK
23	2	ADJ SAFETY STOP
22	1	STOP BALL
21	1	CYLINDER CLEVIS
20	2	GUIDE (CARTRIDGE)
19	2	UPPER CHARGE GUIDE
18	2	LOWER CHARGE GUIDE
17	1	DRIVE SHAFT RETAINER
16	1	DRIVE SHAFT KEY
15	1	ROTARY VALVE MACHINERY
14	1	NOZZLE
13	1	RADIAL BEARING
12	1	THRUST BEARING
11	1	GUIDE PLATE MOUNTING
10	1	DRIVE SHAFT
9	1	FIELD SCREW RETAINER
8	1	CARRIAGE CYLINDER
7	1	ROTARY SHUT-OFF CLAP
6	1	BARREL BEARING BRG
5	1	PLASTIC BARREL
4	1	SCREW TIP
3	1	SHUT-OFF SLEEVE
2	1	ADAPTER BRG
1	1	FIELD SCREW
		DESCRIPTION

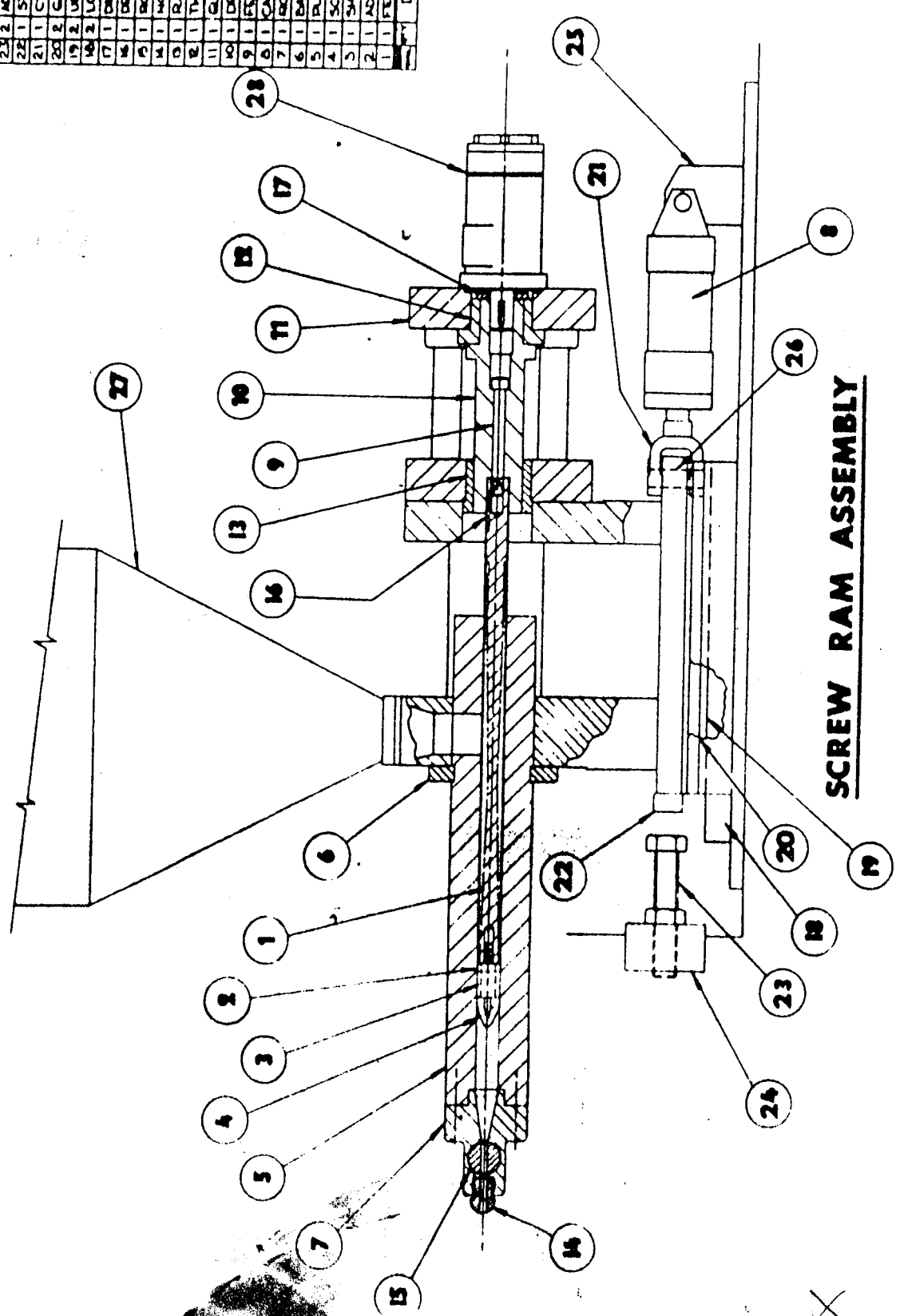

SCREW RAM ASSEMBLY

X

TRUEBLOOD, INC

9215 S State Route 201 • Tipp City Ohio 45371 • Phone (513) 845-3573 • Telex 288-337

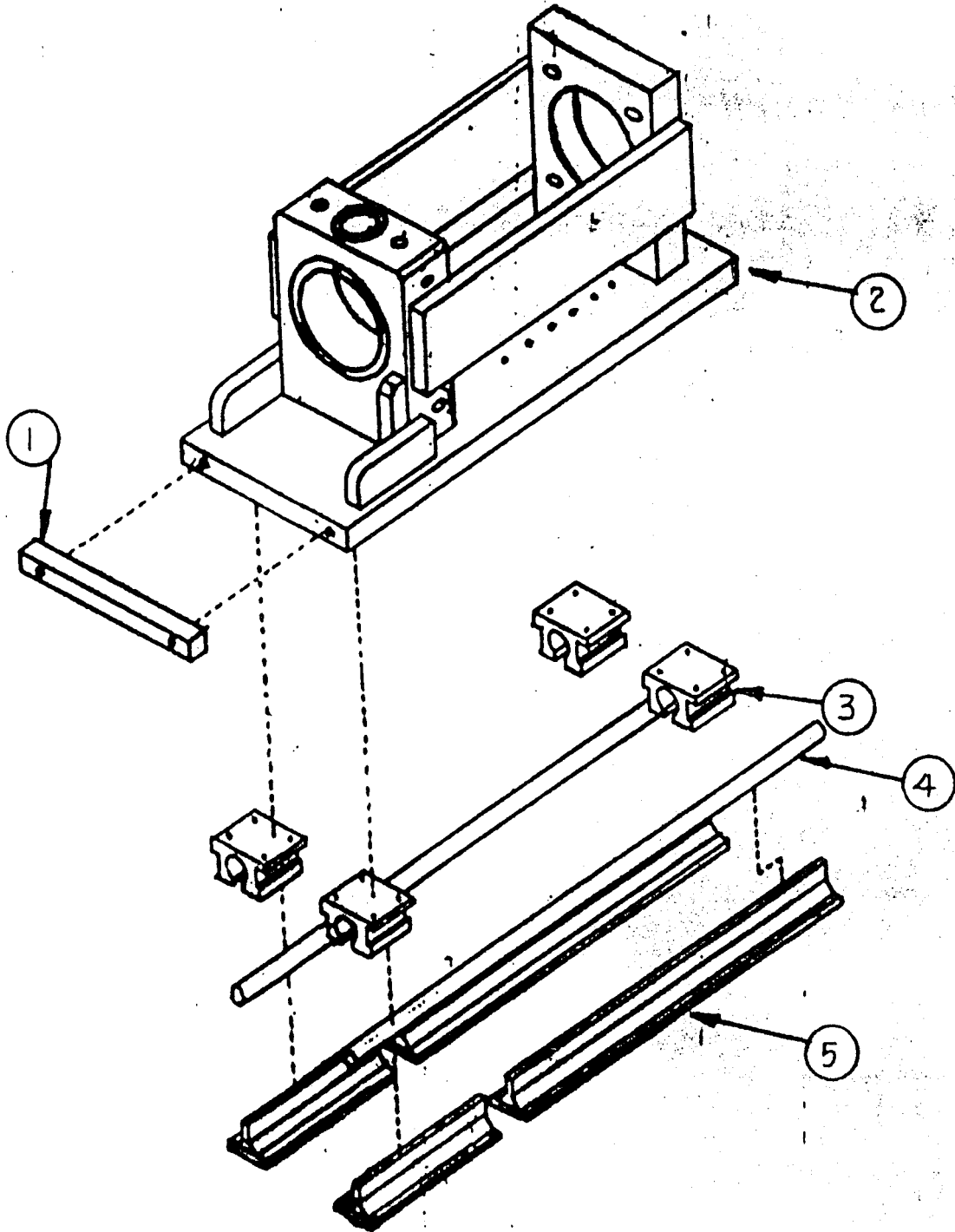

DETAIL #3



X

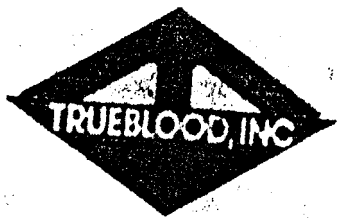

9215 S State Route 201 • Tipp City Ohio 45371 • Phone (513) 845-3573 • Telex 288 337

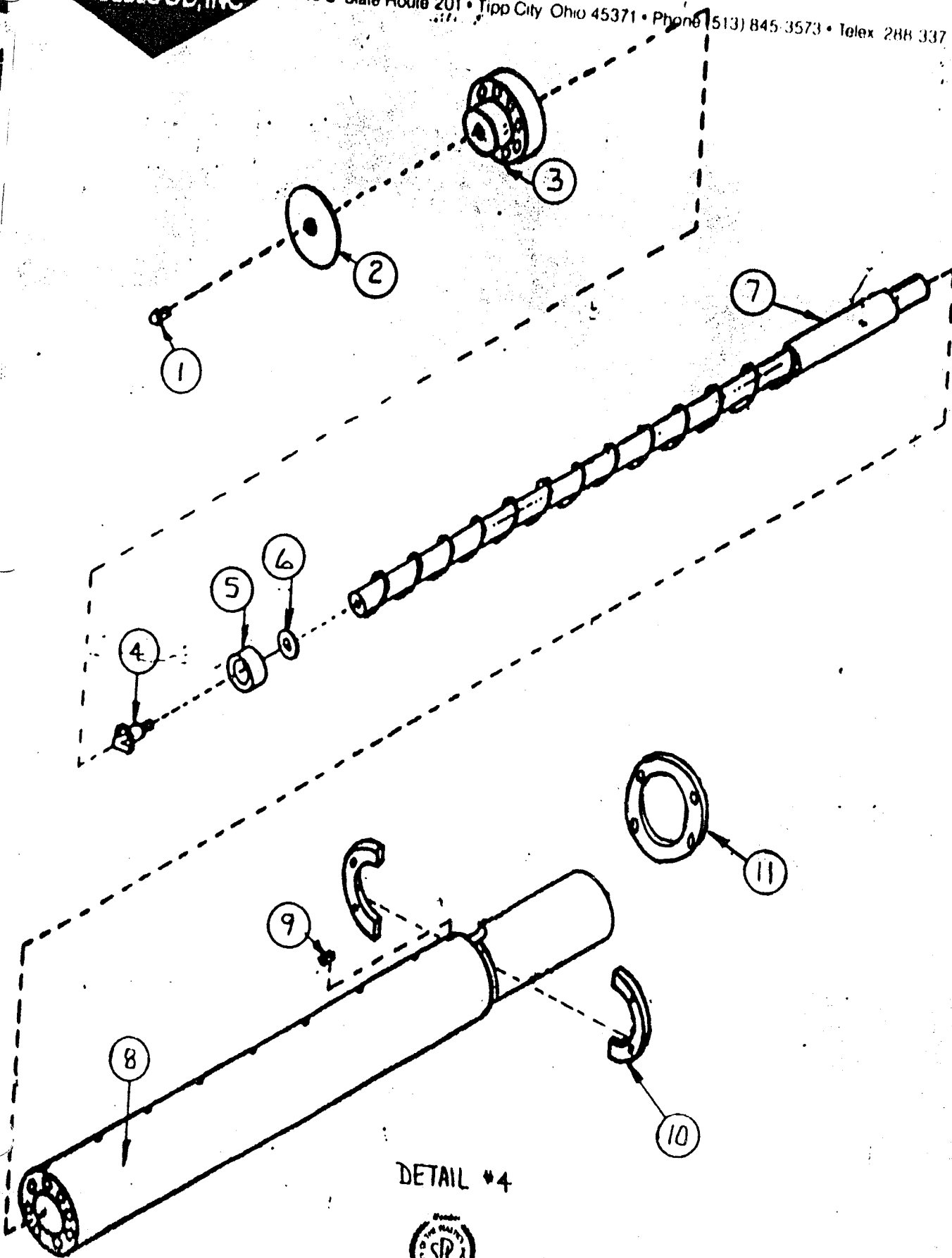

DETAIL #4





9215 S State Route 201 • Tipp City, Ohio 45371 • Phone (613) 846-3573 • Telex 288-337

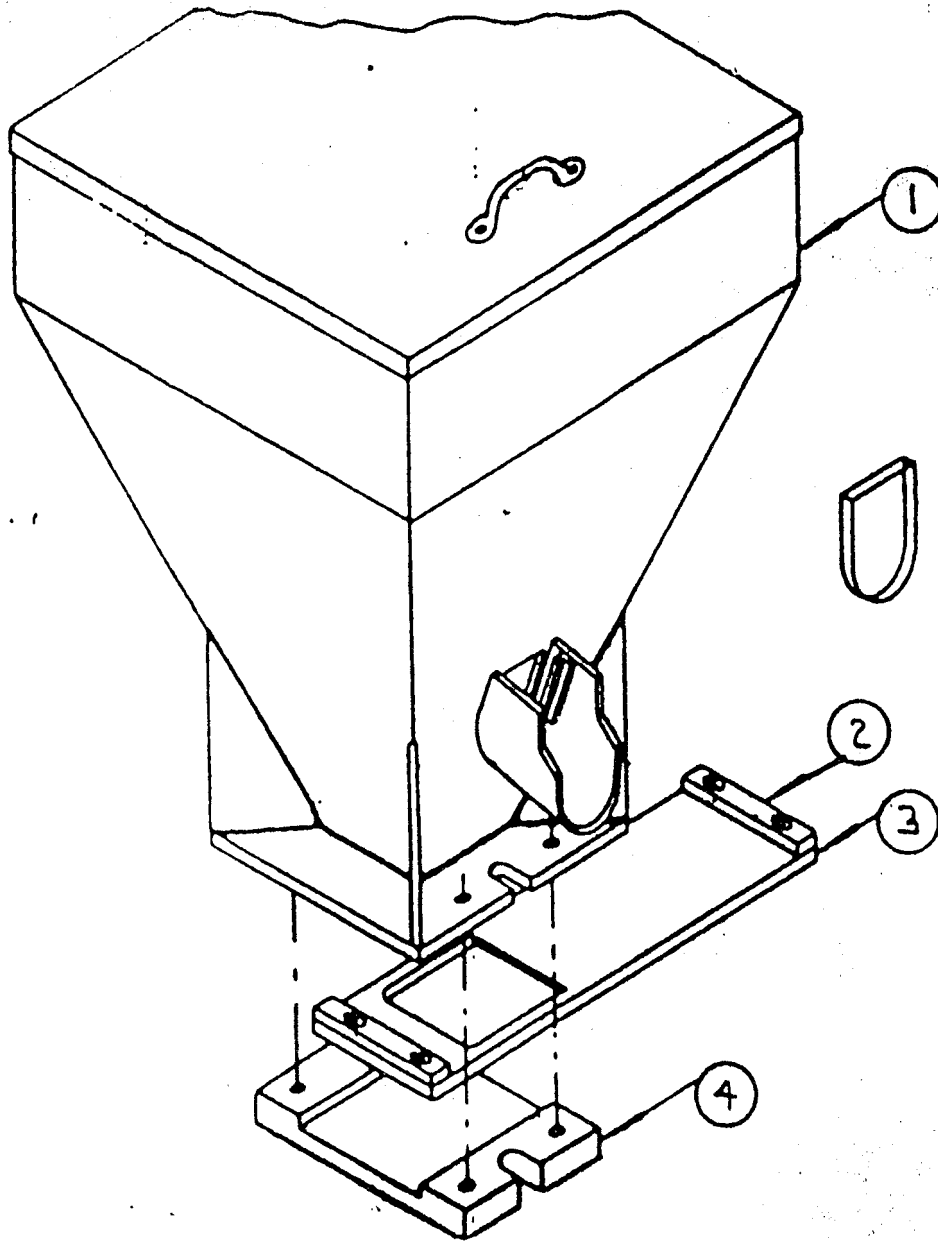

DETAIL #5



X

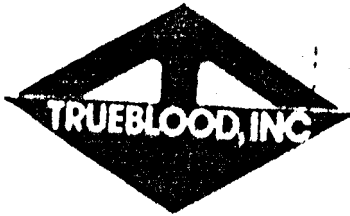

9215 S. State Route 201 • Tipp City, Ohio 45371 • Phone (513) 845-3573 • Telex 288-337

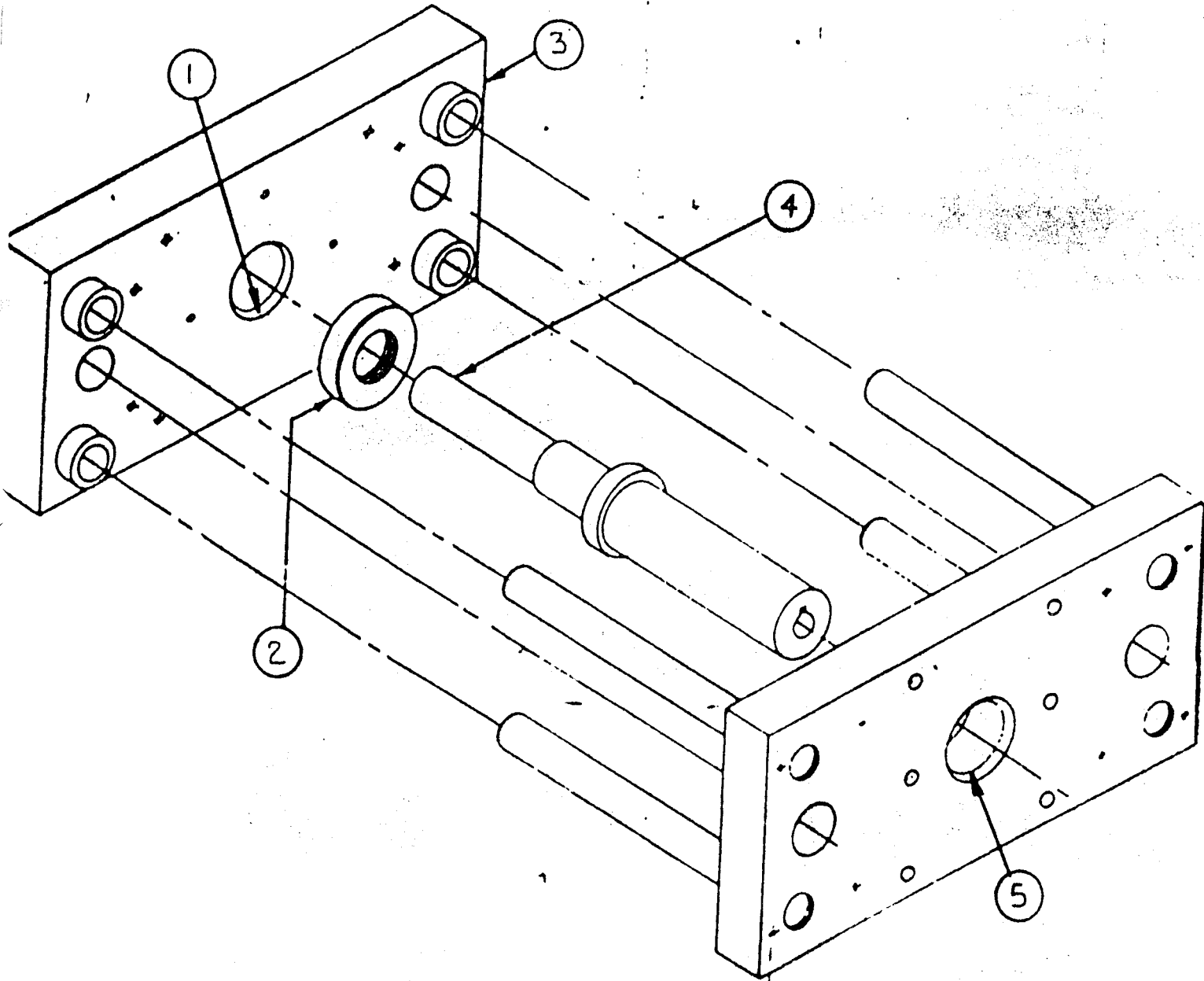

DETAIL '6



4



9215 S State Route 201 • Tipp City, Ohio 45371 • Phone (513) 845-3573 • Telex 288-337

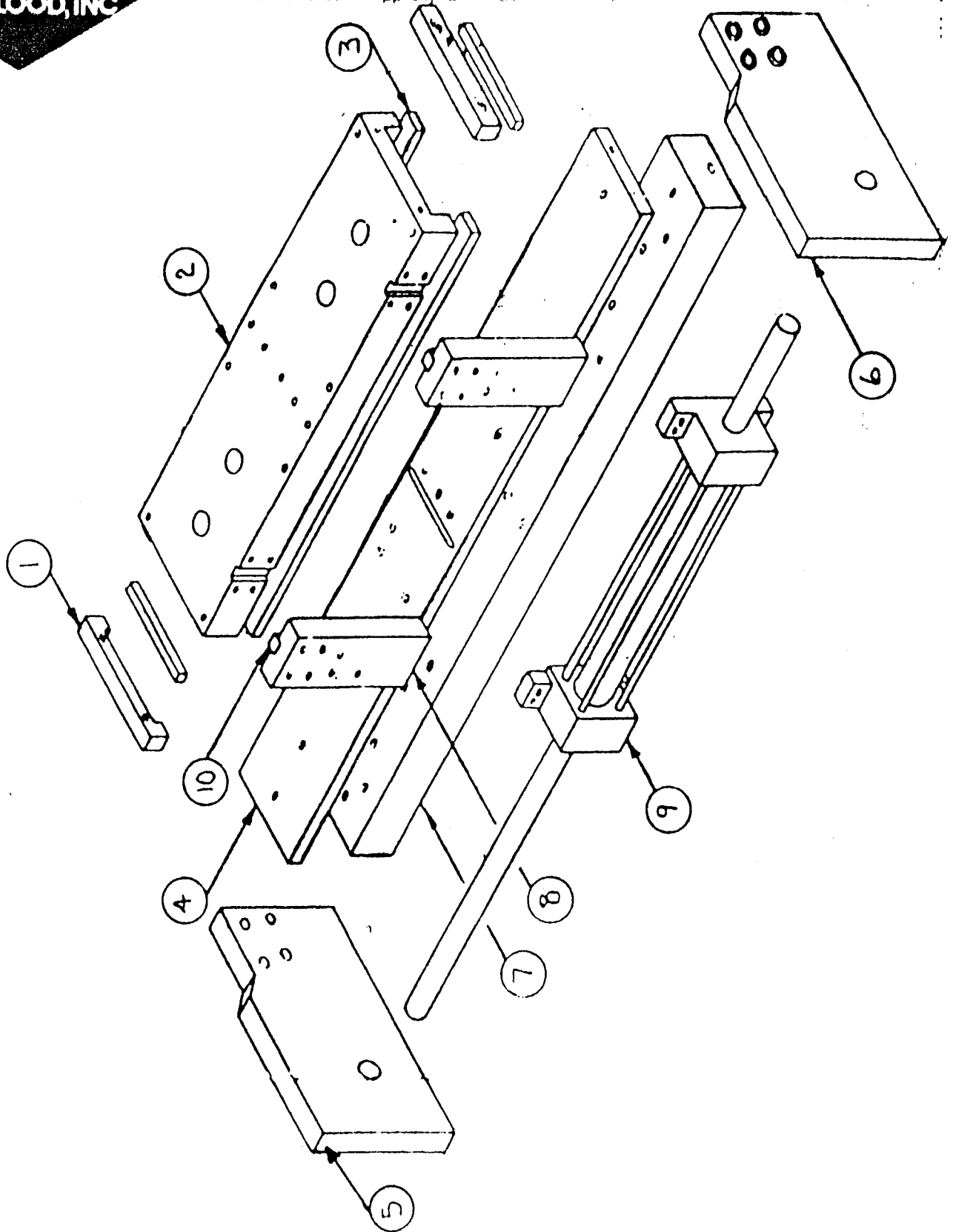

DETAIL #7

8